

Electrical Tape

MAR-MT4651X

Product Description

Plasticized PVS rubber base adhesive.

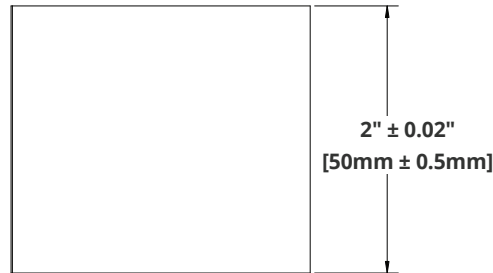
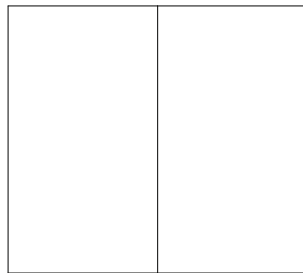
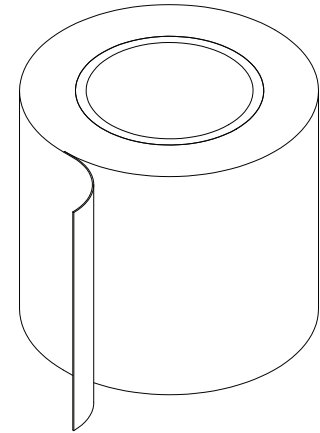
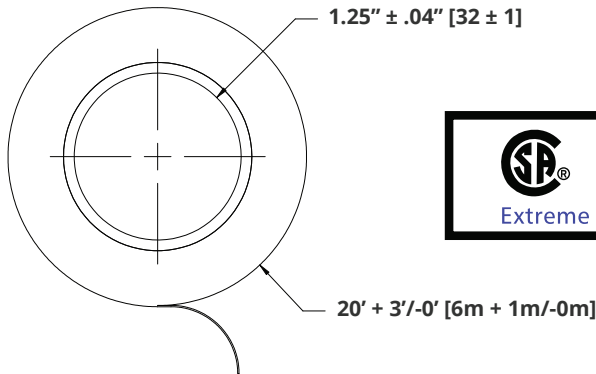

Specifications

Electrical Tape

Inspection Tests @ 23° C & 65% Relative Humidity	Inspection Value	Test Method Specification
Total Thickness	0.19 ± 10%	ASTM D-1000
Adhesion to Steel	0.45 kg/25mm	ASTM D-1000
Adhesion to Backing	0.45 kg/25mm	ASTM D-1000
Tensile Strength	14 Mpa	ASTM D-1000
Elongation	100%	ASTM D-1000
Dielectric Breakdown	7.0 kv	ASTM D-1000
Flammability	pass	UL-510
Temperature Resistance	-10°C to 80°C	UL-510

Notes: 1. All metric dimensions are in brackets..

2. Material: Plasticized PVS rubber base adhesive.