

MAR-TWRHDITX, Acetal Banding Installation Tool

Product Description

Durable, all steel construction with comfortable plastic handles

Tool Weight: 9 oz. (256 gr.)

Installs All LH, H, & EH cross section cable ties.

Cable tie cross-section code:

LH = Light Heavy H = Heavy EH = Extra Heavy

This Tool's Features Include:

- Single handle trigger for fast installation
- Cable tie side entry for immediate positioning of tie and tool
- One hand operation – lightweight
- Installer controlled tension
- Cut-off capability with the twist of the wrist
- Easy removal of excess tie

Specifications

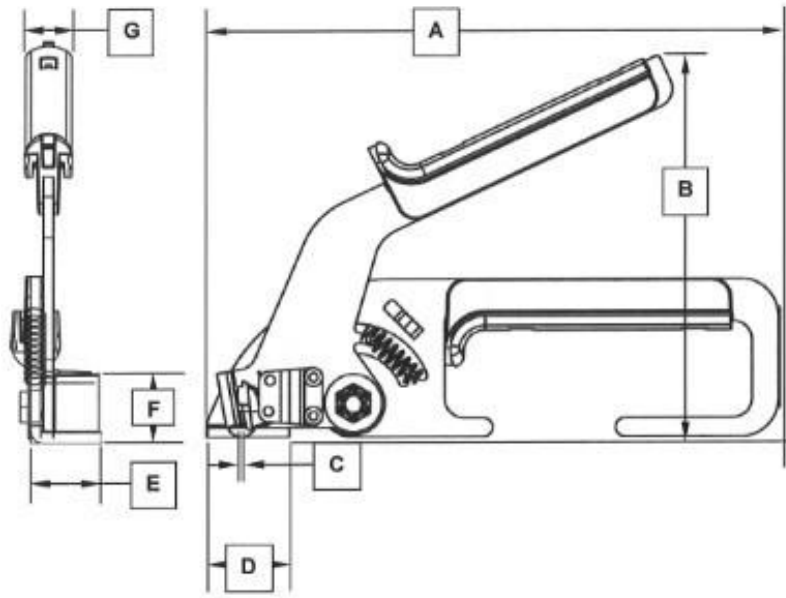

Dimensions shown in parentheses are (mm) metric:

A = 7.500" (190.50) OVERALL LENGTH

B = 5.000" (127.00) OPEN HANDLE SPAN

C = 0.098" W x .604 L (2.49 W x 15.24 L) TIE ENTRY

D = 1.063" (27.00) HEIGHT OF HEAD

E = 0.875" (22.23) DEPTH OF HEAD

F = 0.875" (22.23) WIDTH OF HEAD

G = 0.500" (12.70) DEPTH OF HANDLE

Marathon products are available from the following distributors:

Wesco

buy.wesco.com
866.746.3519

Anixter

Anixter.com
866.746.3519